

HIPERTEC DACH

Anwendung: Dach
Verlegerichtung: -



DETAIL FIRST

VERTIKALSCHNITT FIRST

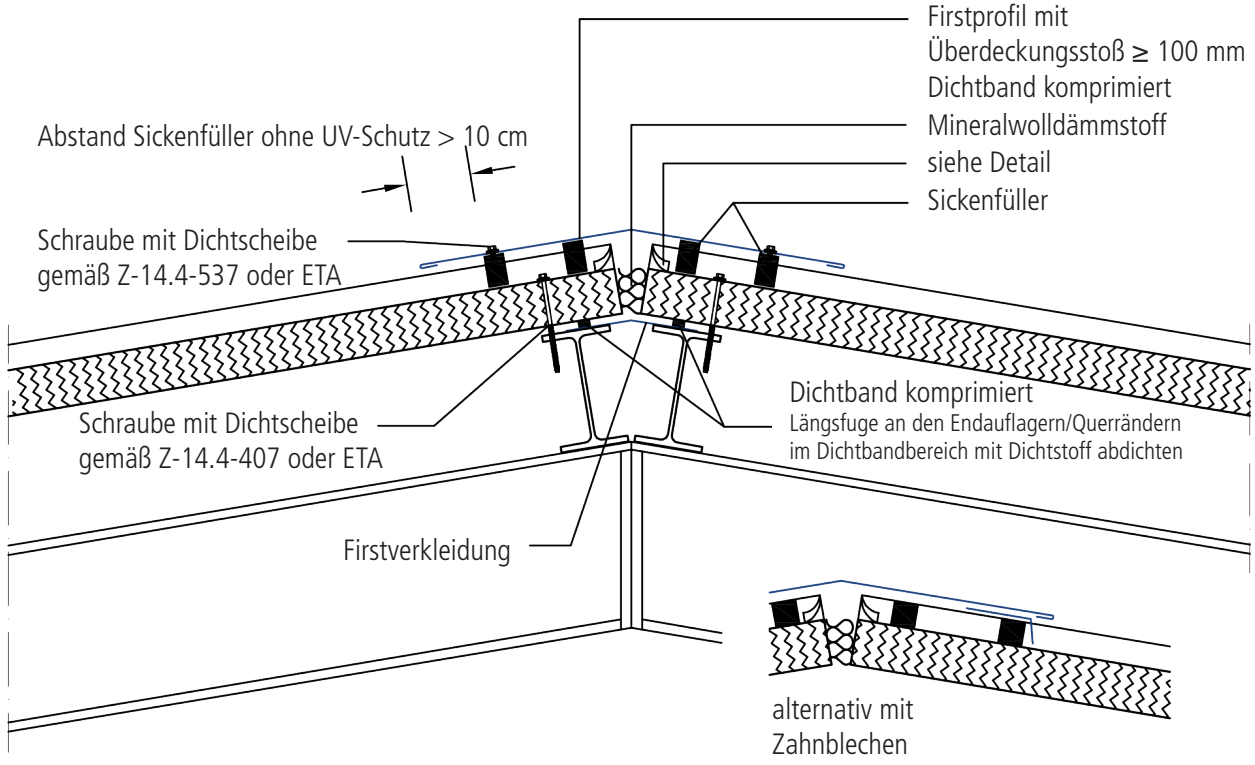

DETAIL

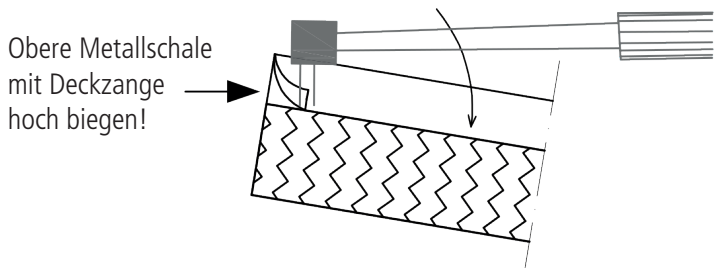

Zeichnungsnummer: 03.01.01/-

Änderungen vorbehalten · Stand 03/21

Firstprofil Best.-Nr.: KT-FIR 01 Zuschnitt: 610 Lmax = 5000	
Firstverkleidung Best.-Nr.: KT-FIR 10 Zuschnitt: 305 Lmax = 6000	



HIPERTEC DACH

Anwendung: Dach
 Verlegerichtung: -



DETAIL FIRST (mit Zahnblech)

VERTIKALSCHNITT FIRST

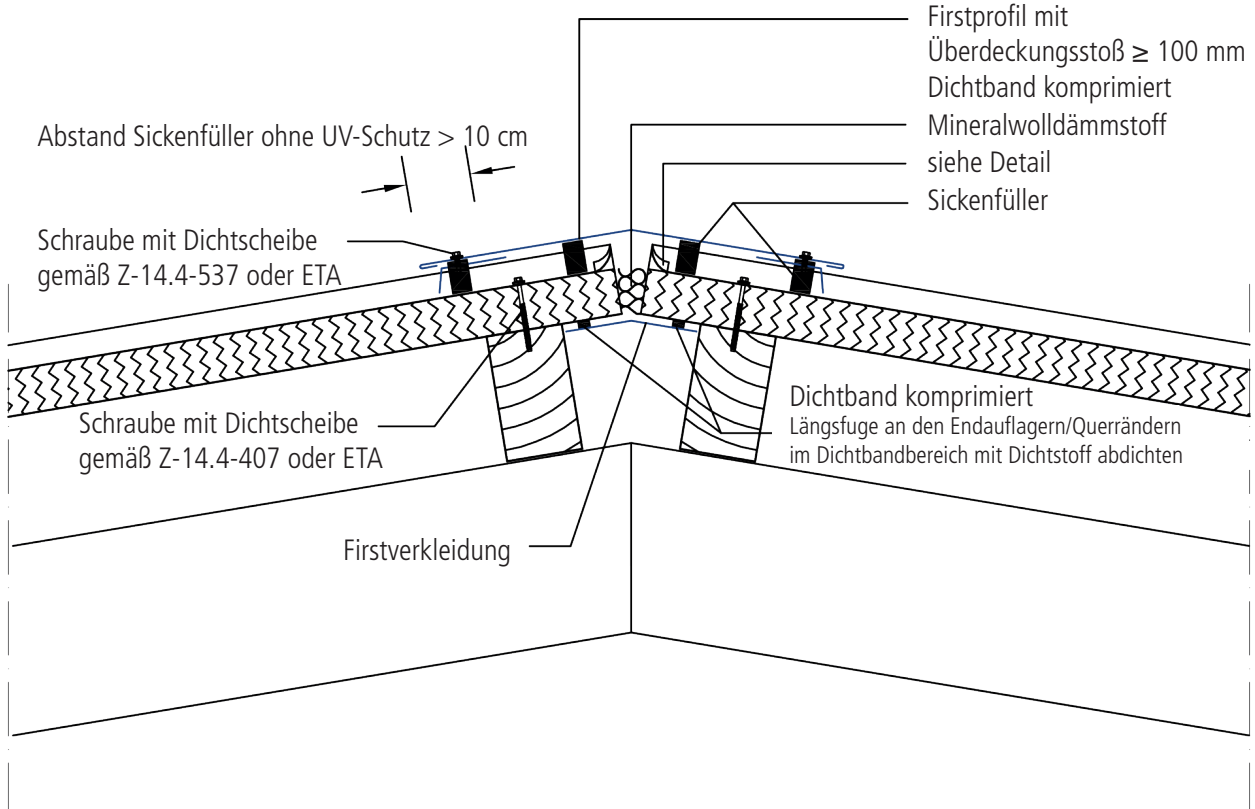

DETAIL

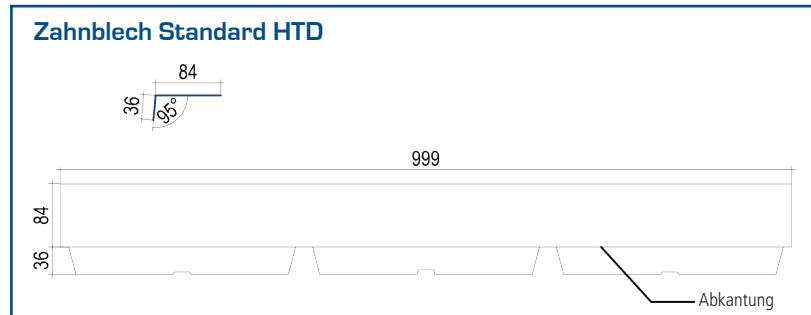
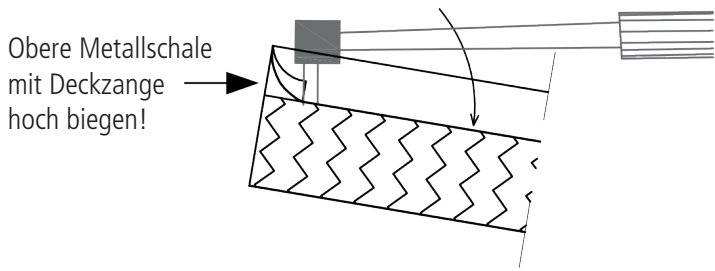

Firstprofil
 Best.-Nr.: KT-FIR 01

Zuschnitt: 610
 Lmax = 5000

Firstverkleidung
 Best.-Nr.: KT-FIR 10

Zuschnitt: 305
 Lmax = 6000

Zeichnungsnummer: 03.01.02/-

Änderungen vorbehalten · Stand 03/21



HIPERTEC DACH

Anwendung: Dach
 Verlegerichtung: -



DETAIL PULTFIRST (ohne Dachüberstand)

VERTIKALSCHNITT PULTFIRST (OHNE DACHÜBERSTAND)

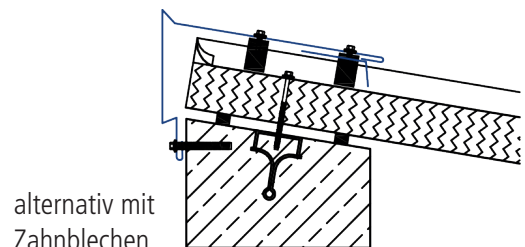
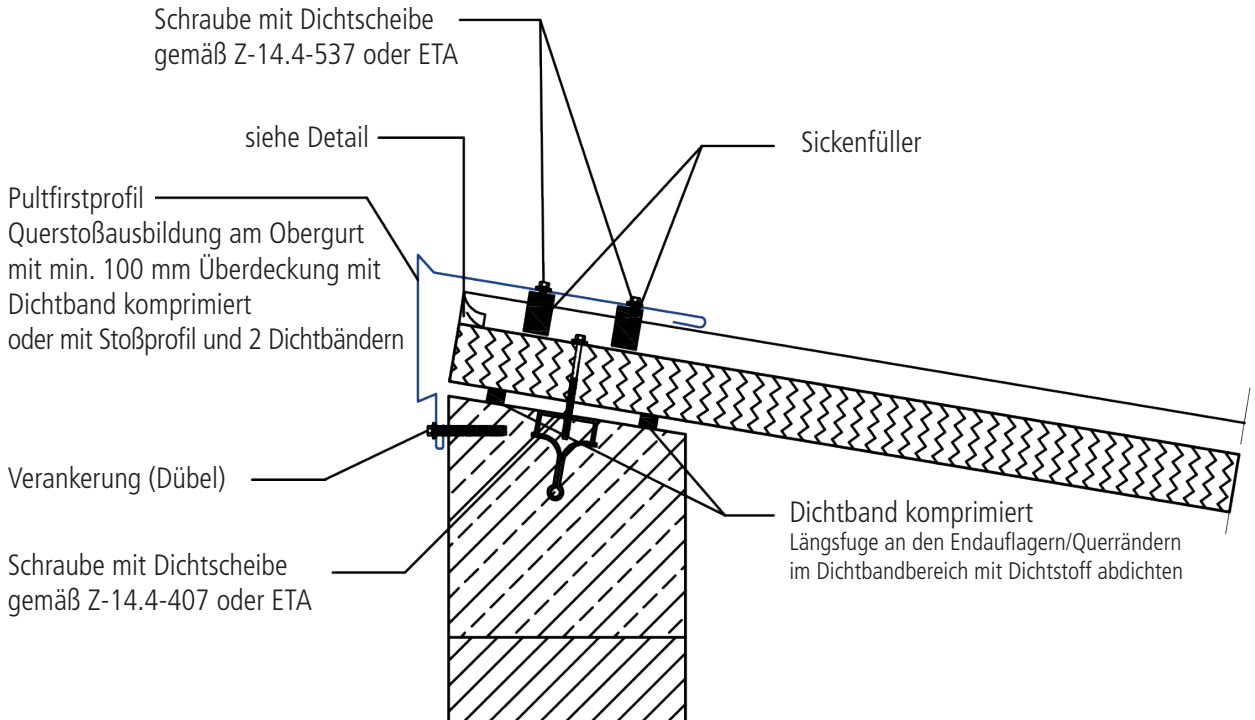

DETAIL

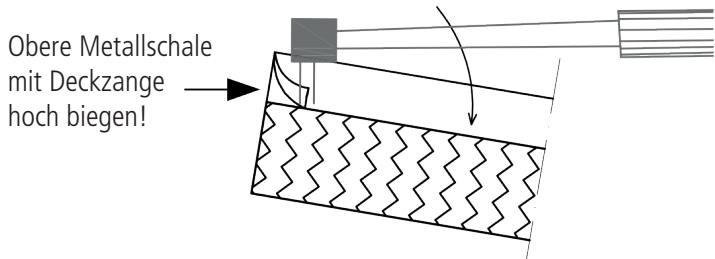

Pultfirstprofil
Best.-Nr.: KT-FIR 04+KZ

Lmax = 5000

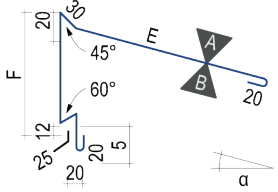

Dämmstoffdicke	30	40	50	60	80	100	120	150	200
Kennzahl	3	4	5	6	8	10	12	15	20
E	244	244	244	244	244	244	244	337	287
F	160	160	160	160	160	221	221	250	300
Z	549	549	549	549	549	610	610	732	732

Zeichnungsnummer: 03.01.03/-

Änderungen vorbehalten · Stand 03/21



HIPERTEC DACH

Anwendung: Dach
 Verlegerichtung: -



DETAIL PULTFIRST (mit Dachüberstand)

VERTIKALSCHNITT PULTFIRST (MIT DACHÜBERSTAND)

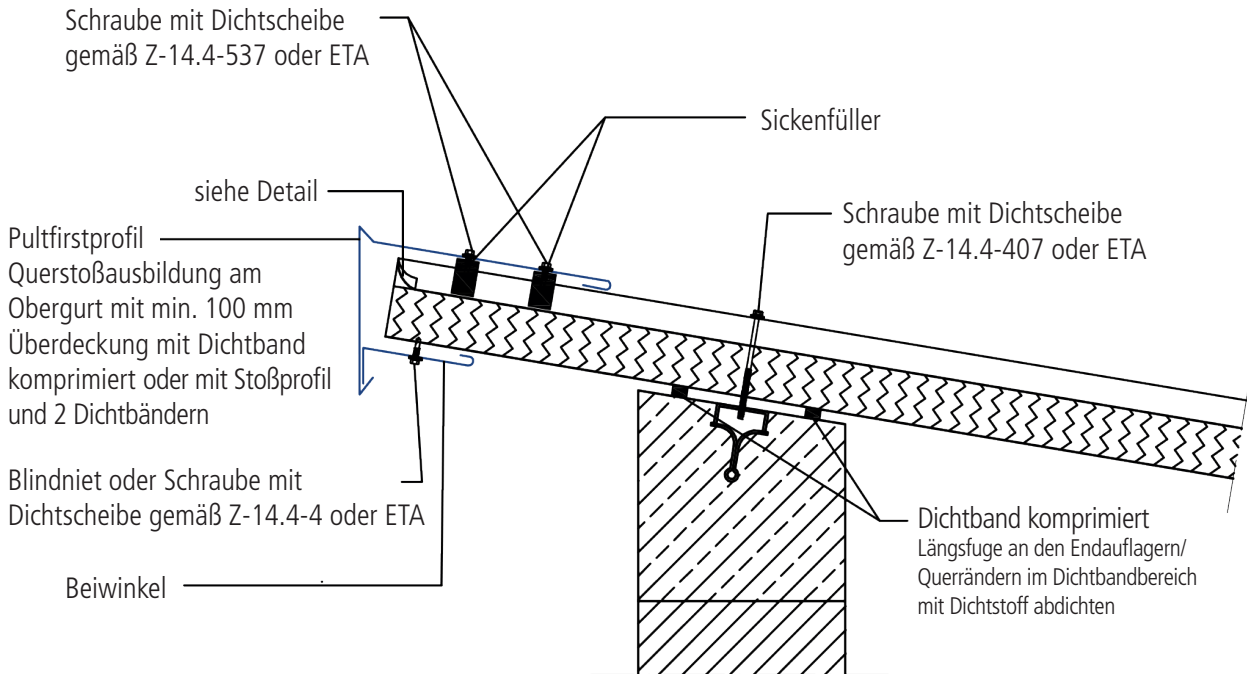

DETAIL

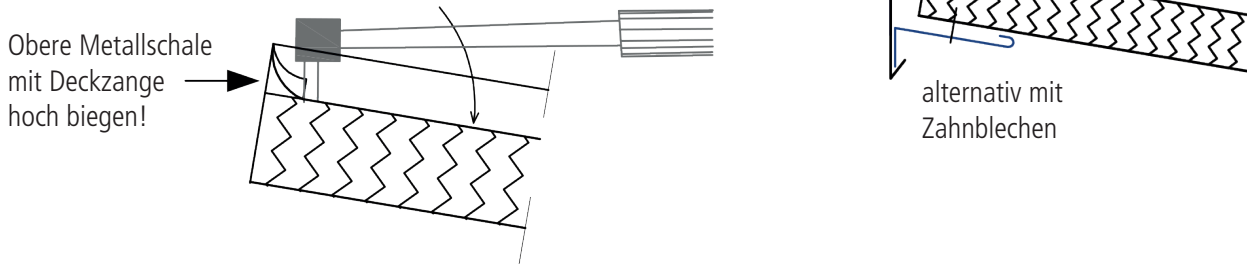

Pultfirstprofil Best.-Nr.: KT-FIR 08+KZ

Lmax = 5000

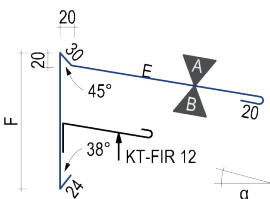

Dämmstoffdicke	30	40	50	60	80	100	120	150	200
Kennzahl	3	4	5	6	8	10	12	15	20
E	249	249	249	249	249	249	249	286	358
F	185	185	185	185	185	226	226	250	300
Z	508	508	508	508	508	549	549	610	732

Beiwinkel Best.-Nr.: KT-FIR 12+KZ

Lzu KT-FIR 08 und KT-FIR 09

Lmax = 6000

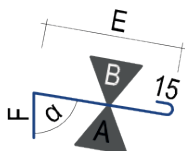

Dämmstoffdicke	30	40	50	60	80	100	120	150	200
Kennzahl	3	4	5	6	8	10	12	15	20
E	98	108	118	99	119	128	119	153	153
F	90	80	70	60	40	60	40	35	35
Z	203	203	203	174	174	203	174	203	203

Zeichnungsnummer: 03.01.04/-

Änderungen vorbehalten · Stand 03/21



HIPERTEC DACH

Anwendung: Dach
 Verlegerichtung: -



DETAIL TRAUFE

VERTIKALSCHNITT TRAUFE

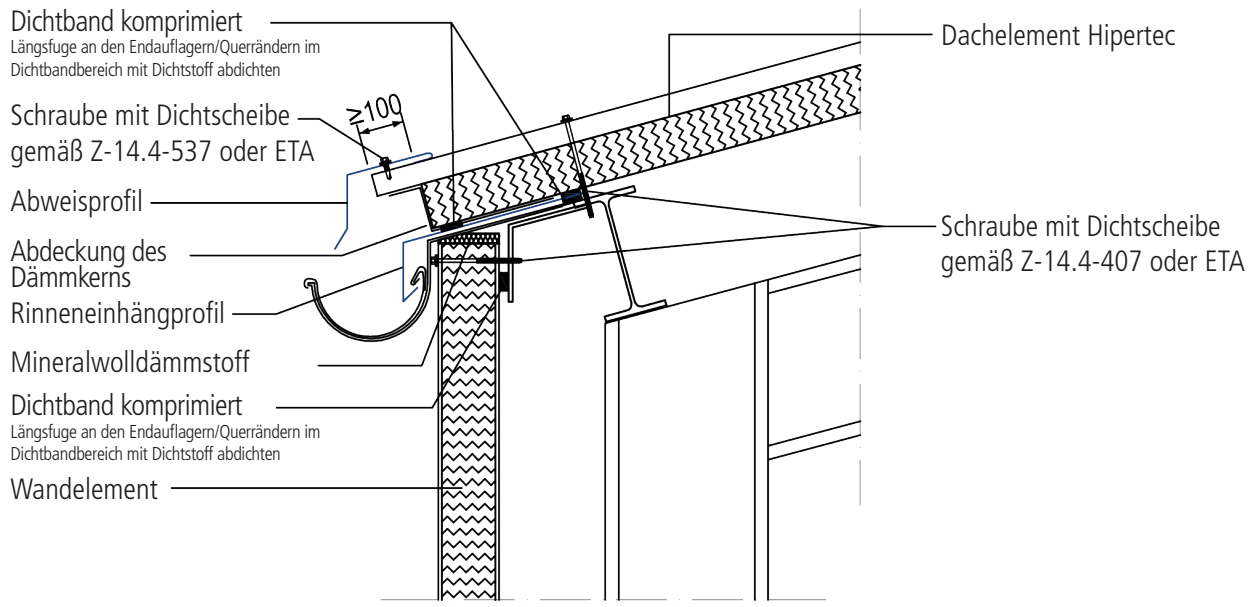
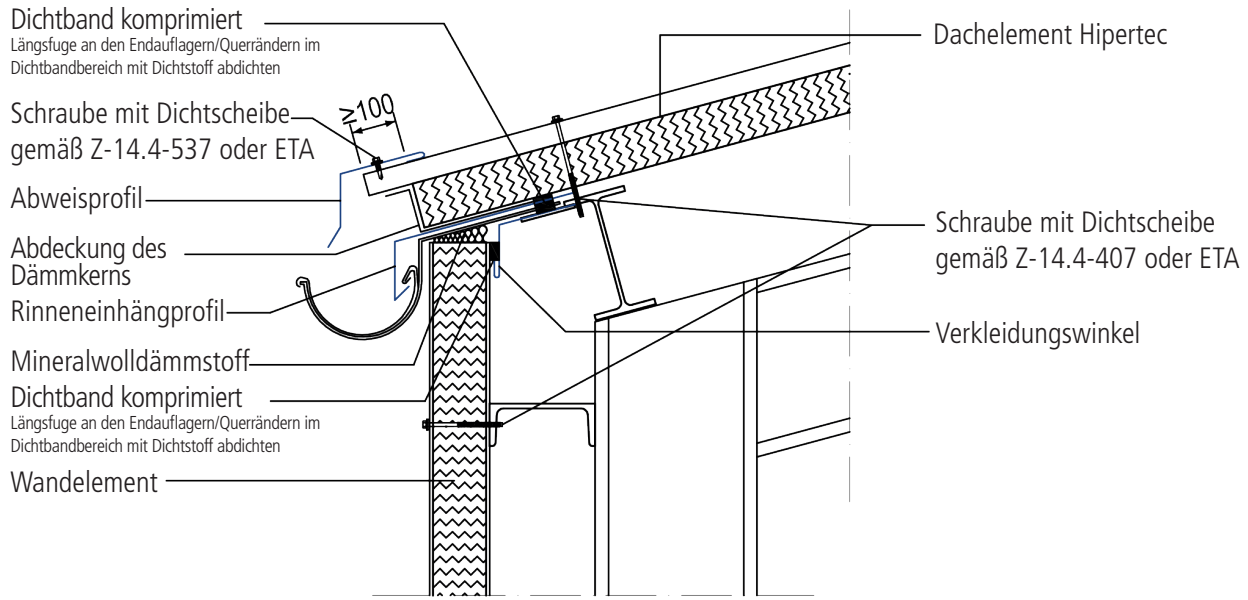

Zeichnungsnummer: 03.02.01/-

Änderungen vorbehalten · Stand 03/21

Rinneneinhängprofil
Best.-Nr.: KT-TRA 01

Zuschnitt: 244
 Lmax = 6000

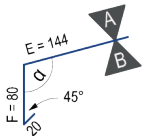

Verkleidungswinkel
Best.-Nr.: KT-TRA 09

Zuschnitt: 203
 Lmax = 6000

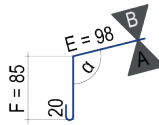

Abweisprofil
Best.-Nr.: KT-TRA 05+KZ

Lmax = 6000

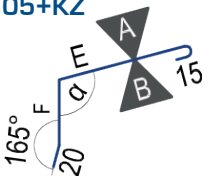

Dämmstoffdicke	30	40	50	60	80	100	120	150	200
Kennzahl	3	4	5	6	8	10	12	15	20
E	108	139	129	119	160	140	120	191	200
F	60	70	80	90	110	130	150	180	230
Z	203	244	244	244	305	305	305	406	406



HIPERTEC DACH

Anwendung: Dach
 Verlegerichtung: -



DETAIL TRAUFE

VERTIKALSCHNITT TRAUFE

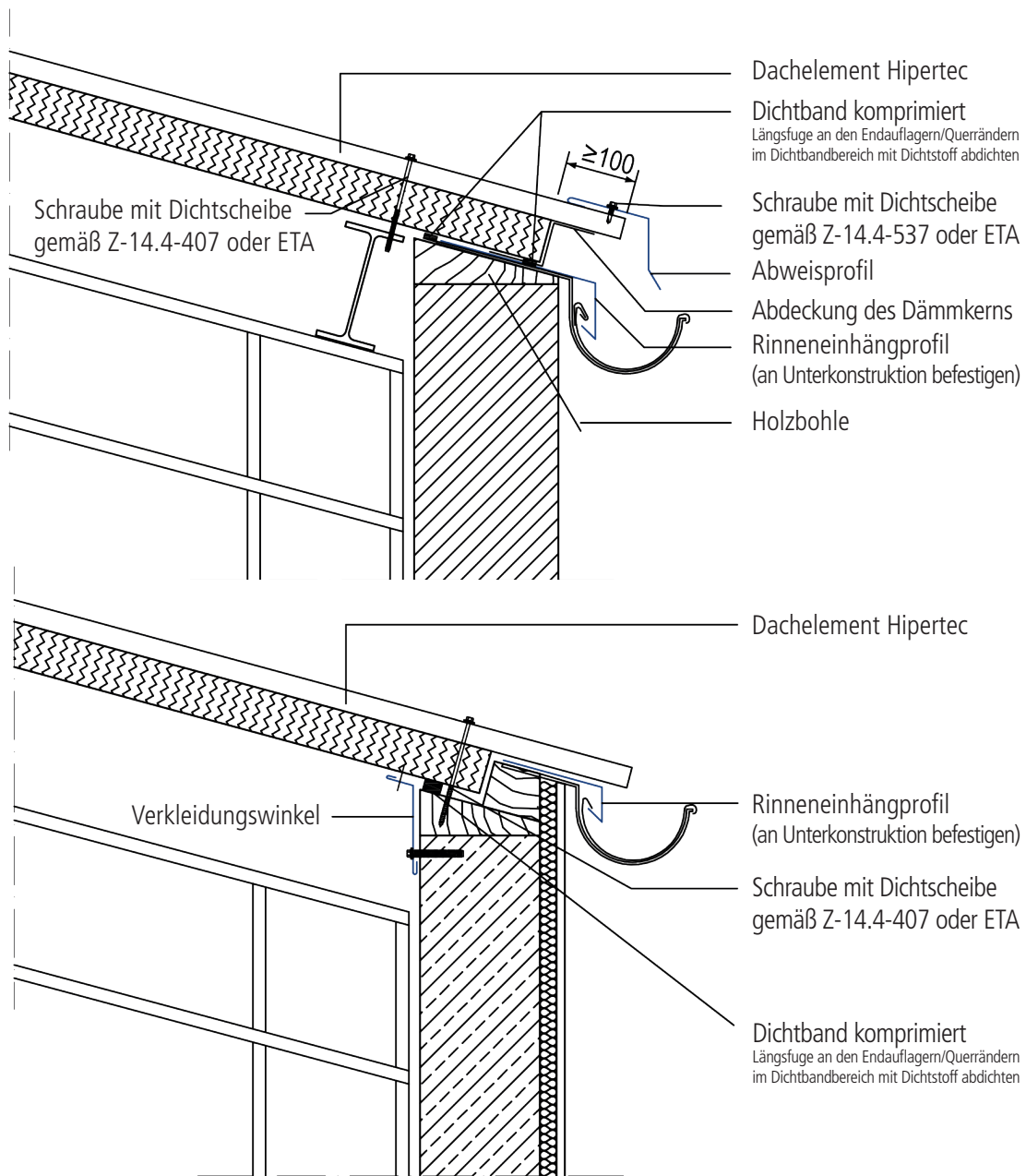

Rinneneinhängprofil
Best.-Nr.: KT-TRA 01

Zuschnitt: 244
 Lmax = 6000

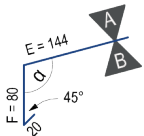

Verkleidungswinkel
Best.-Nr.: KT-TRA 10

Zuschnitt: 174
 Lmax = 6000

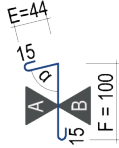

Abweisprofil
Best.-Nr.: KT-TRA 05+KZ

Lmax = 6000

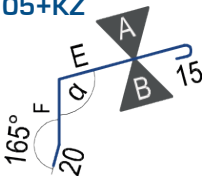

Dämmstoffdicke	30	40	50	60	80	100	120	150	200
Kennzahl	3	4	5	6	8	10	12	15	20
E	108	139	129	119	160	140	120	191	200
F	60	70	80	90	110	130	150	180	230
Z	203	244	244	244	305	305	305	406	406

Zeichnungsnummer: 03.02.02/-

Änderungen vorbehalten · Stand 03/21



HIPERTEC DACH

Anwendung: Dach
 Verlegerichtung: -



DETAIL TRAUFE (Dachüberstand)

VERTIKALSCHNITT TRAUFE

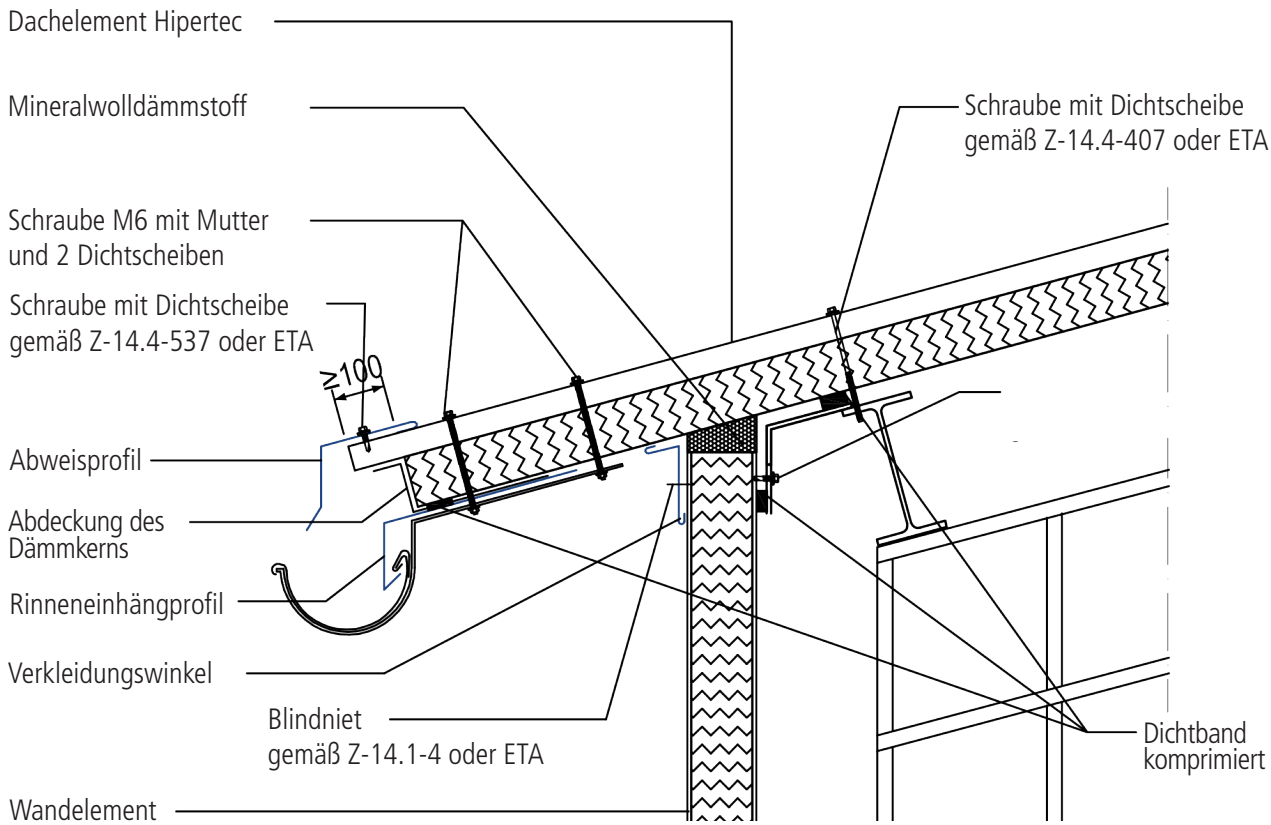

Zeichnungsnummer: 03.02.03/-

Änderungen vorbehalten · Stand 03/21

Rinneneinhängprofil
Best.-Nr.: KT-TRA 01

Zuschnitt: 244
 Lmax = 6000

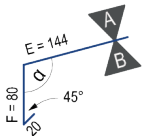

Verkleidungswinkel
Best.-Nr.: KT-TRA 10

Zuschnitt: 174
 Lmax = 6000

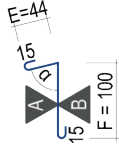

Abweisprofil
Best.-Nr.: KT-TRA 05+KZ

Lmax = 6000

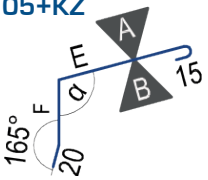

Dämmstoffdicke	30	40	50	60	80	100	120	150	200
Kennzahl	3	4	5	6	8	10	12	15	20
E	108	139	129	119	160	140	120	191	200
F	60	70	80	90	110	130	150	180	230
Z	203	244	244	244	305	305	305	406	406



HIPERTEC DACH

Anwendung: Dach
 Verlegerichtung: -



DETAIL ORTGANG/WANDANSCHLUSS

VERTIKALSCHNITT ORTGANG/WANDANSCHLUSS

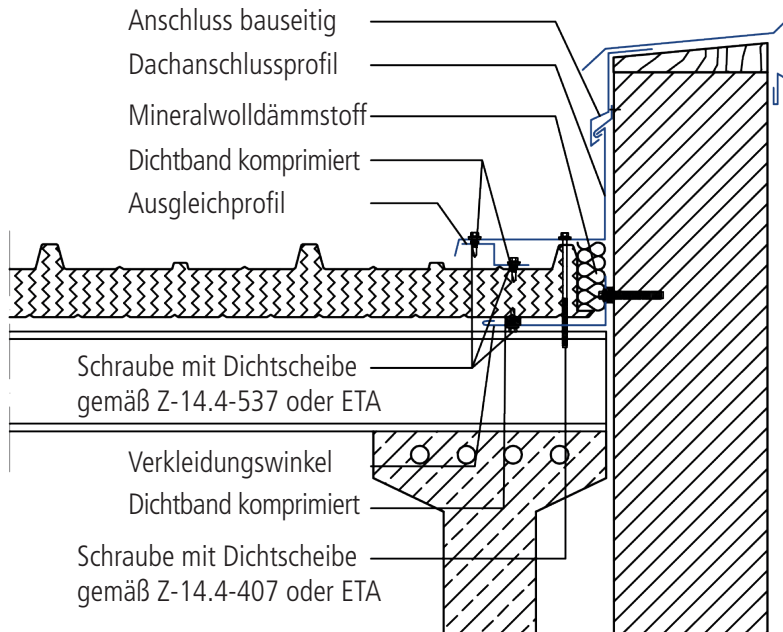

<p>Dachanschlussprofil Best.-Nr.: KT-DAN 10</p> <p>Zuschnitt: 436 Lmax = 6000</p>	<p>Ausgleichprofil Best.-Nr.: KT-ORT 07</p> <p>Zuschnitt: 122 Lmax = 6000</p>	<p>Verkleidungswinkel Best.-Nr.: KT-ORT 14</p> <p>Zuschnitt: 174 Lmax = 6000</p>
---	---	--

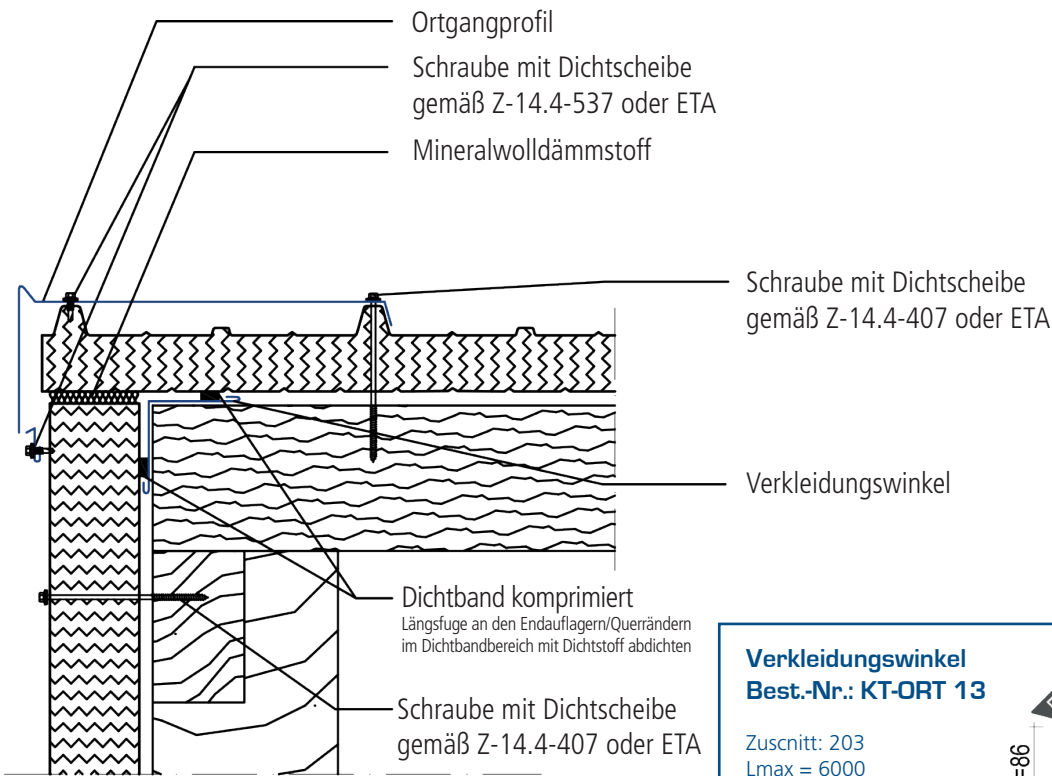

<p>Verkleidungswinkel Best.-Nr.: KT-ORT 13</p> <p>Zuschnitt: 203 Lmax = 6000</p>
--

Zeichnungsnummer: 03.03.01/-
 Änderungen vorbehalten · Stand 03/21



HIPERTEC DACH

Anwendung: Dach
 Verlegerichtung: -



DETAIL ORTGANG

VERTIKALSCHNITT TRAUFE

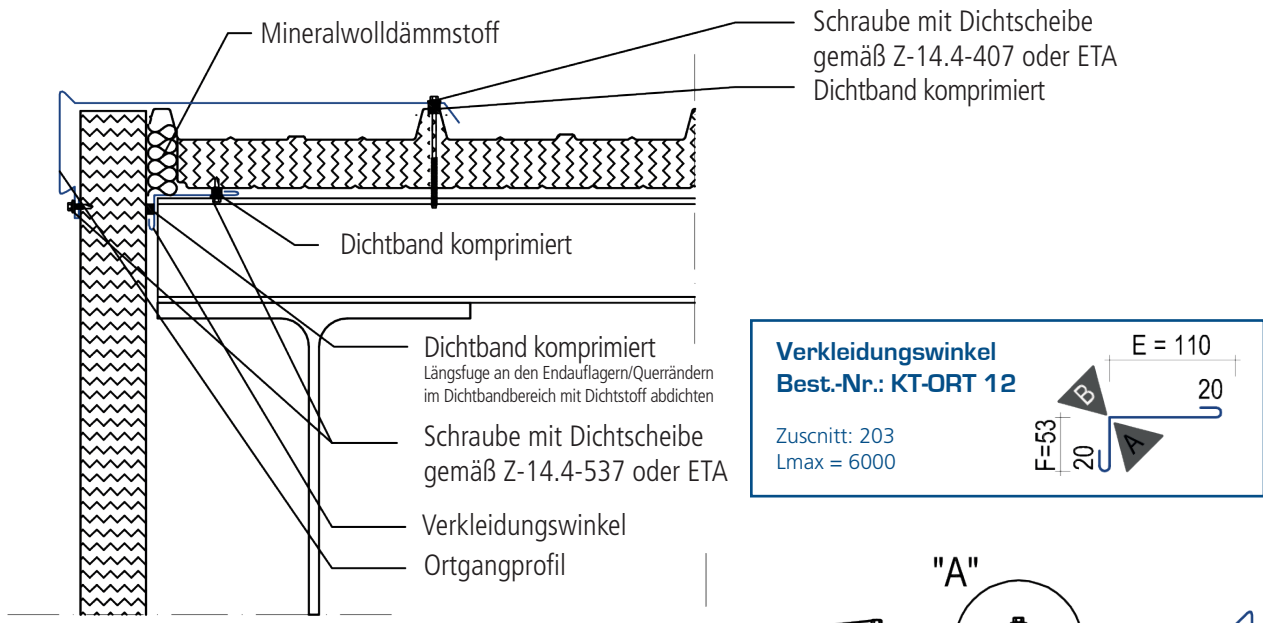

Verkleidungswinkel
Best.-Nr.: KT-ORT 12

Zuschnitt: 203
 Lmax = 6000

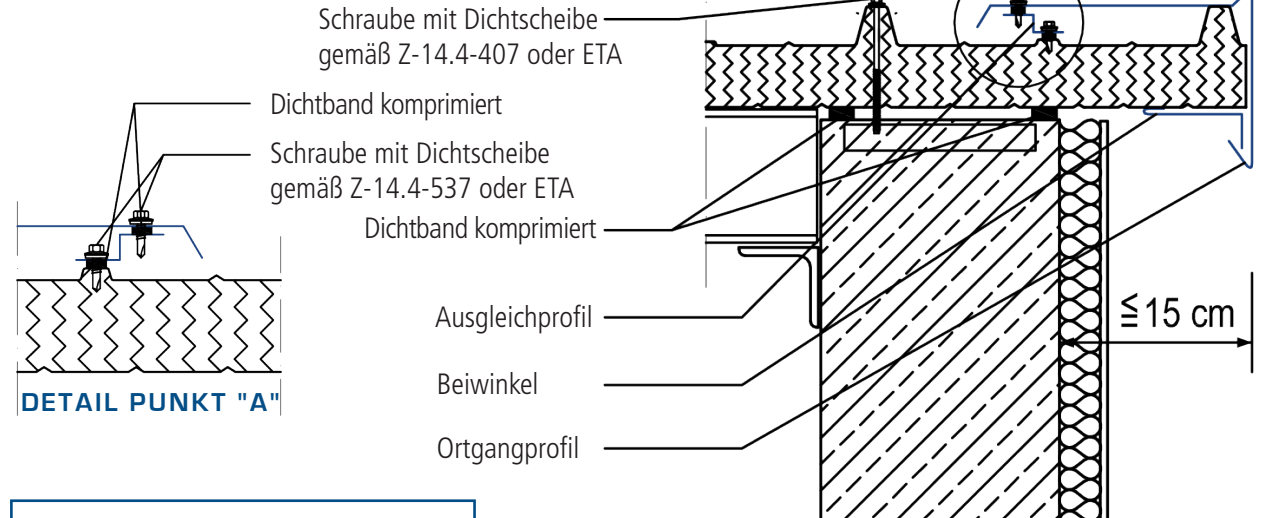

Ausgleichprofil
Best.-Nr.: KT-ORT 07

Zuschnitt: 122
 Lmax = 6000

Ortgangprofil
Best.-Nr.: KT-ORT 03+KZ
 Lmax = 5000

Dämmstoffdicke	30	40	50	60	80	100	120	150	200
Kennzahl	3	4	5	6	8	10	12	15	20
E	239	239	239	239	239	239	239	276	348
F	185	185	185	185	185	226	226	250	300
Z	508	508	508	508	508	549	549	610	732

Beiwinkel
Best.-Nr.: KT-ORT 09+KZ
 zu KT-ORT 03
 Lmax = 6000

Dämmstoffdicke	30	40	50	60	80	100	120	150	200
Kennzahl	3	4	5	6	8	10	12	15	20
E	98	108	118	99	119	128	119	153	153
F	90	80	70	60	40	60	40	35	35
Z	203	203	203	174	174	203	174	203	203

Zeichnungsnummer: 03.03.02/-

Änderungen vorbehalten · Stand 03/21



HIPERTEC DACH

Anwendung: Dach
 Verlegerichtung: -

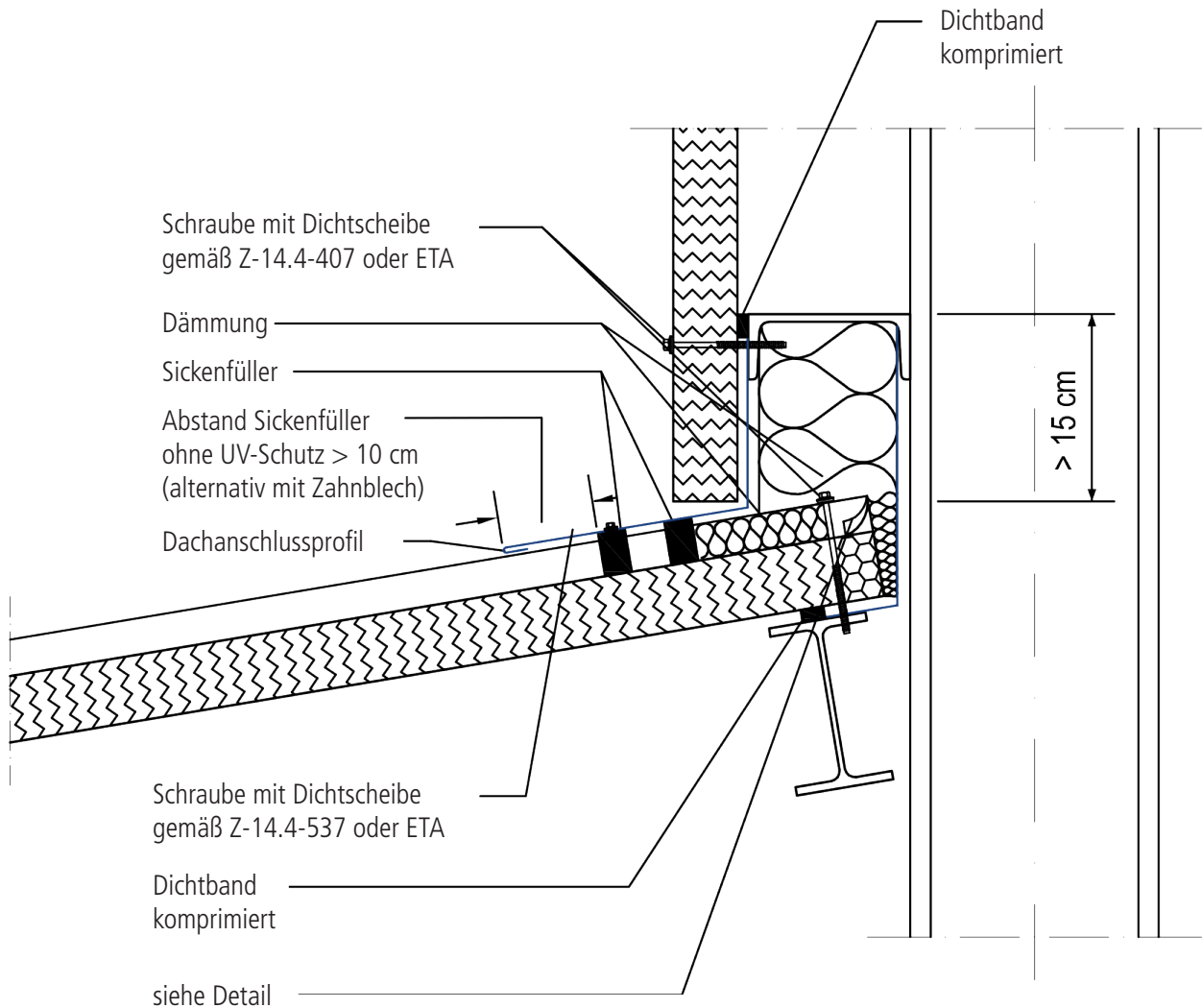
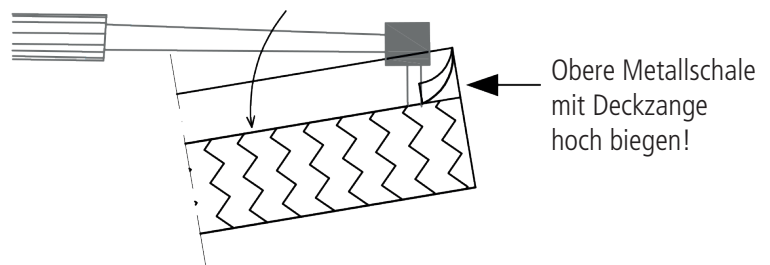
ÜBERGANG DACH/WAND**VERTIKALSCHNITT WANDANSCHLUSS****DETAIL**

Dachanschlussprofil
Best.-Nr.: KT-DAN 01

Zuschnitt: 457
 Lmax = 5000

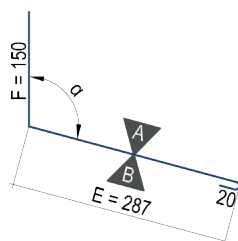

Zeichnungsnummer: 03.04.01/-

Änderungen vorbehalten · Stand 03/21



HIPERTEC DACH

Anwendung: Dach
 Verlegerichtung: -



**WANDANSCHLUSS AN MASSIVBAUTEILE
 QUER ZUR PROFILRICHTUNG**

VERTIKALSCHNITT WANDANSCHLUSS

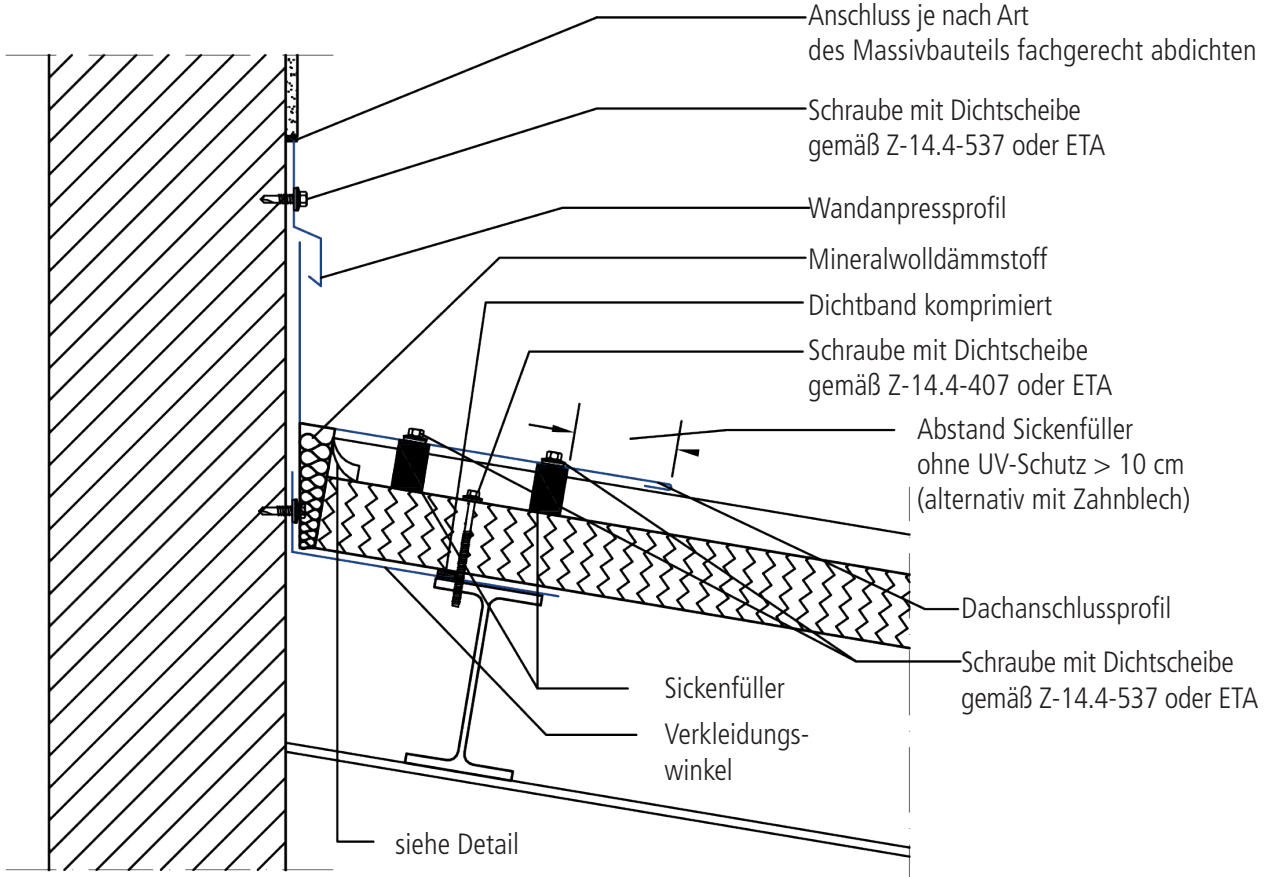

DETAIL

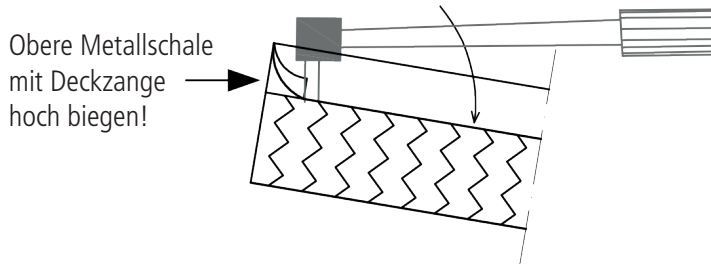

Zeichnungsnummer: 03.04.02/-

Änderungen vorbehalten · Stand 03/21

**Dachanschlussprofil
 Best.-Nr.: KT-DAN 01**

Zuschnitt: 457
 Lmax = 6000

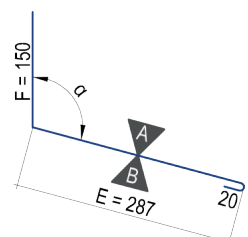

**Verkleidungswinkel
 Best.-Nr.: KT-WAN 16**

Zuschnitt: 110
 Lmax = 5000

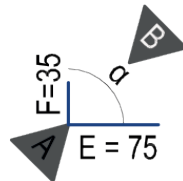

HIPERTEC DACH

Anwendung: Dach
 Verlegerichtung: -



**WANDANSCHLUSS AN MASSIVBAUTEILE
 LÄNGS ZUR PROFILRICHTUNG**

VERTIKALSCHNITT WANDANSCHLUSS

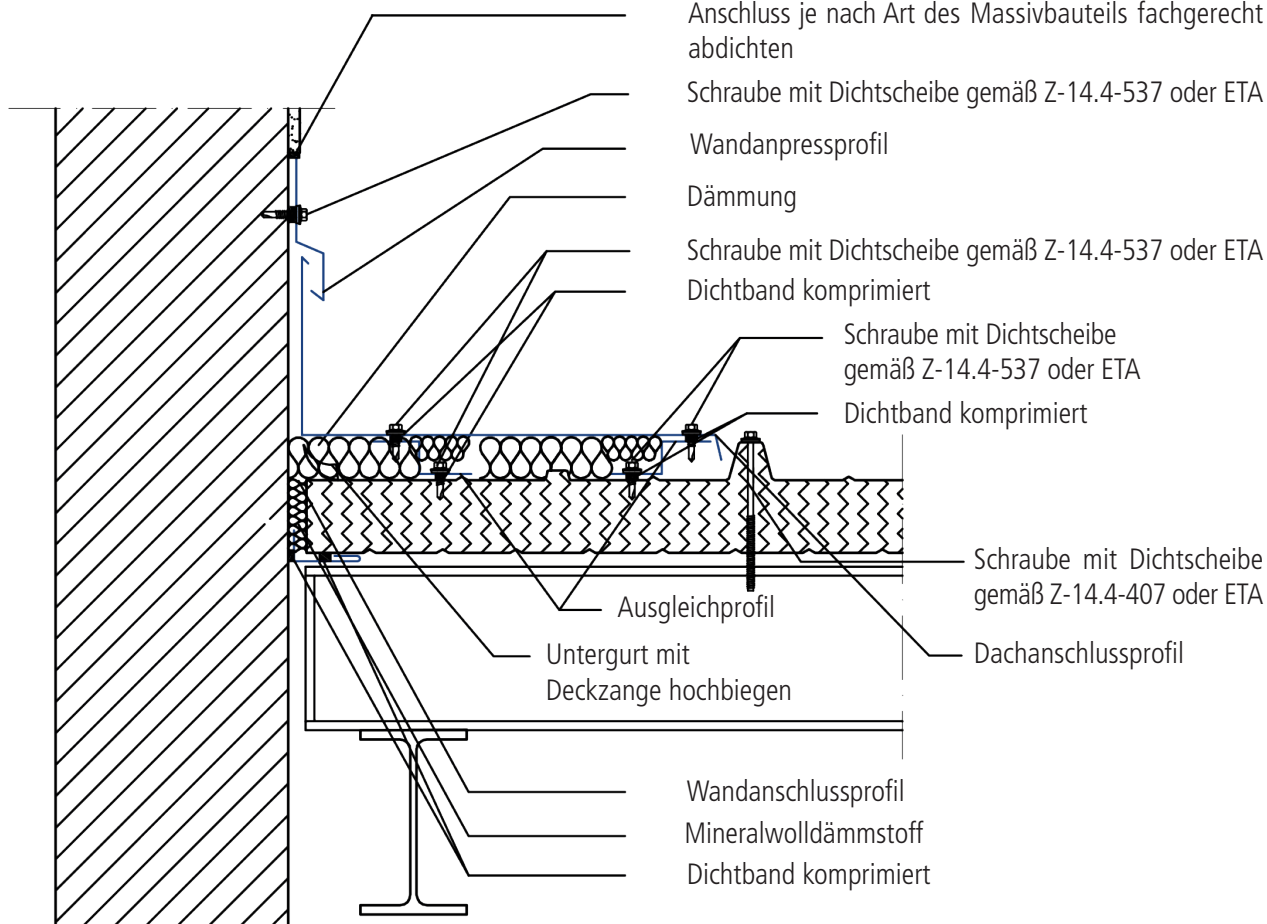

DETAIL

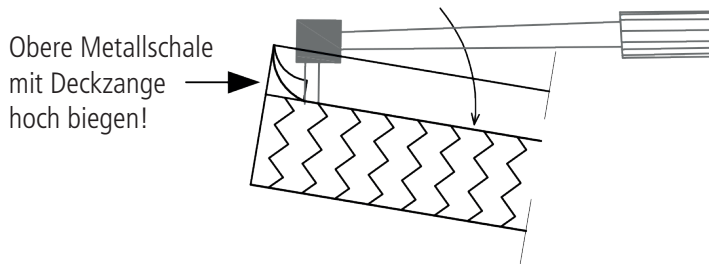

Zeichnungsnummer: 03.04.03/-

Änderungen vorbehalten · Stand 03/21

<p>Dachanschlussprofil Best.-Nr.: KT-DAN 09</p> <p>Zuschnitt: 406 Lmax = 6000</p>	<p>Ausgleichprofil Best.-Nr.: KT-ORT 07</p> <p>Zuschnitt: 122 Lmax = 6000</p>	<p>Wandanschlussprofil Best.-Nr.: KT-WAN 04</p> <p>Zuschnitt: 110 Lmax = 5000</p>
--	--	--



HIPERTEC DACH

Anwendung: Dach
 Verlegerichtung: -

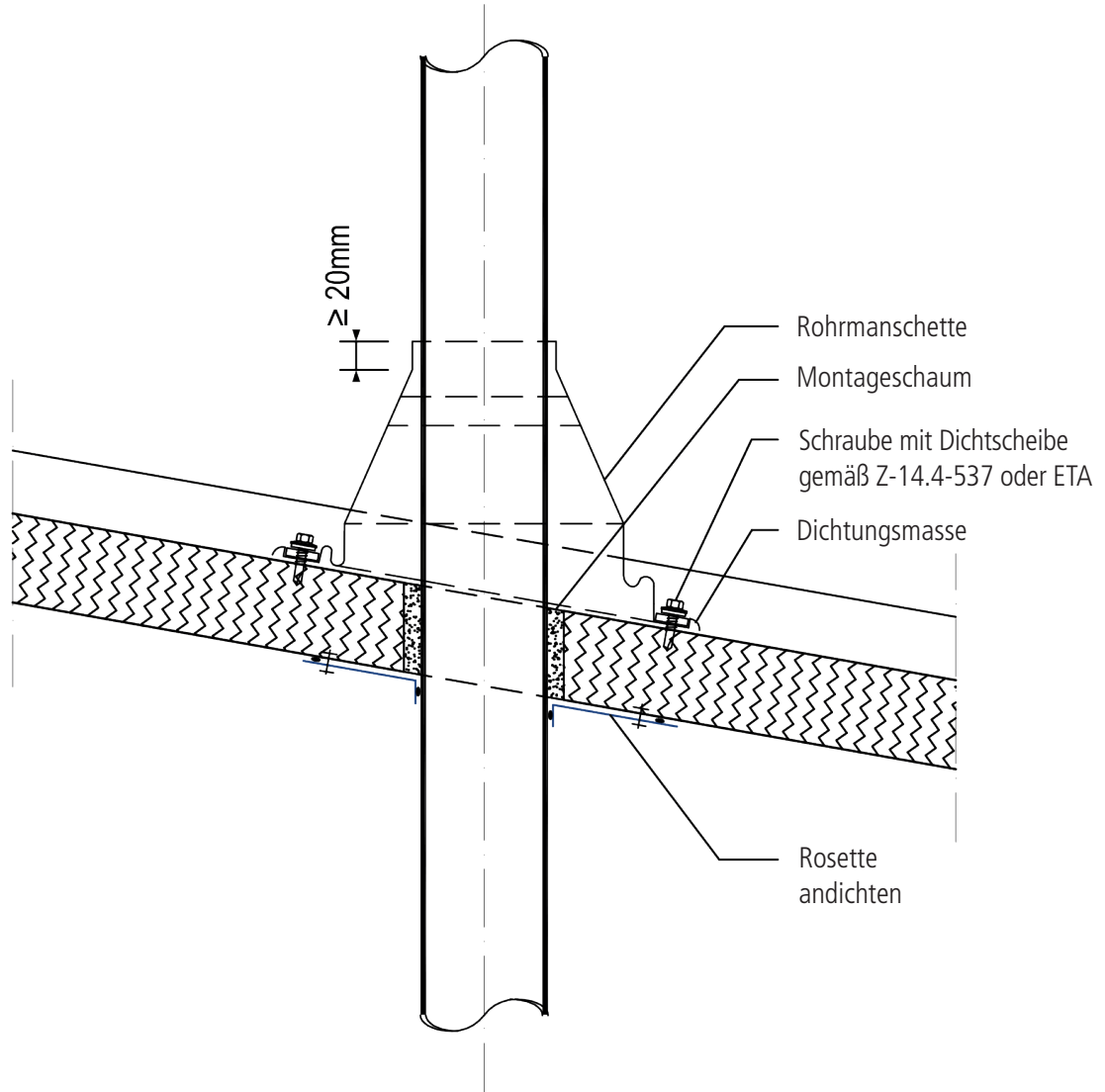
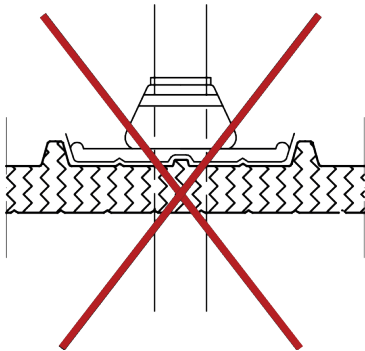
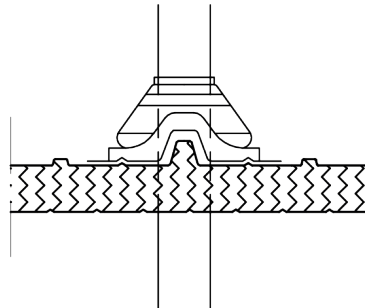
DETAIL ROHRDURCHFÜHRUNG**VERTIKALSCHNITT ROHRDURCHFÜHRUNG****SO NICHT ...****... ABER SO!**

HIPERTEC DACH

Anwendung: Dach
 Verlegerichtung: -

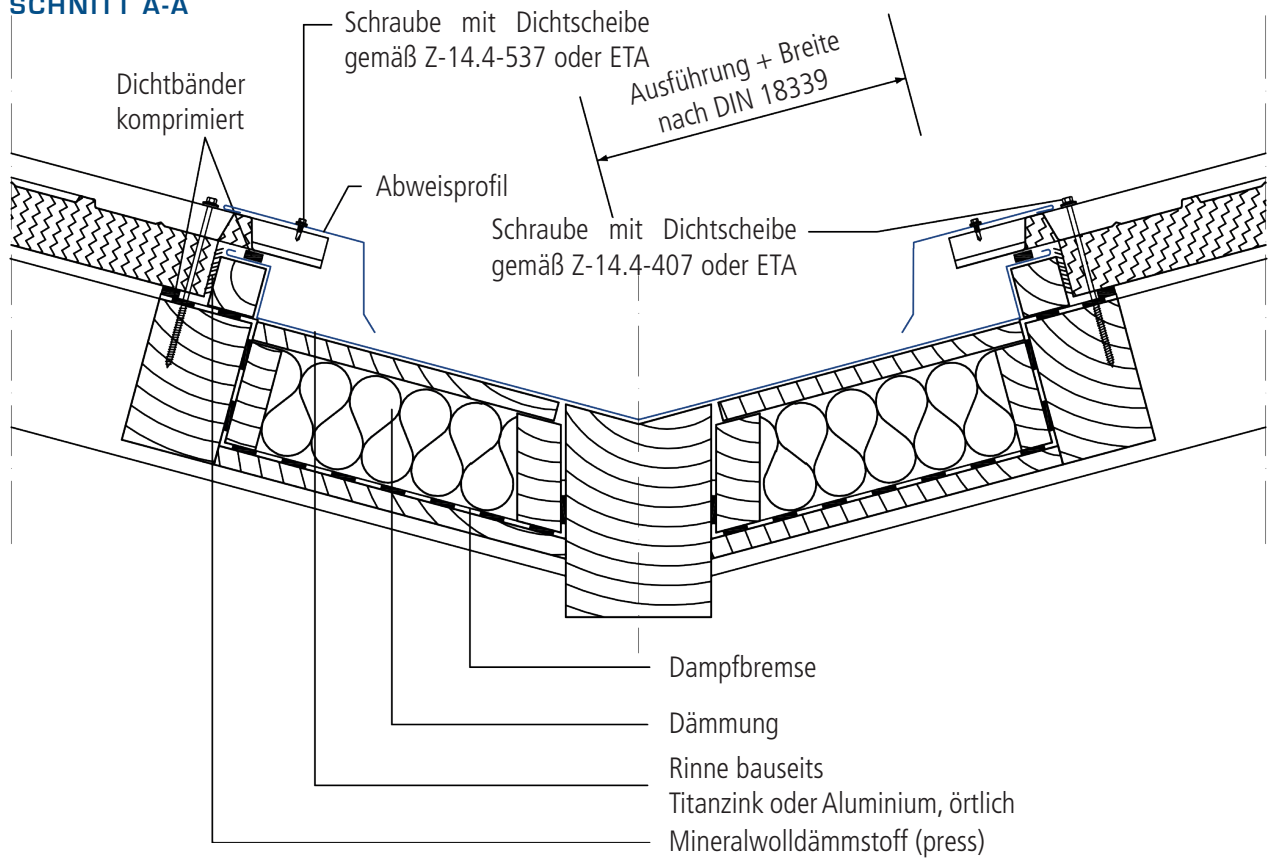
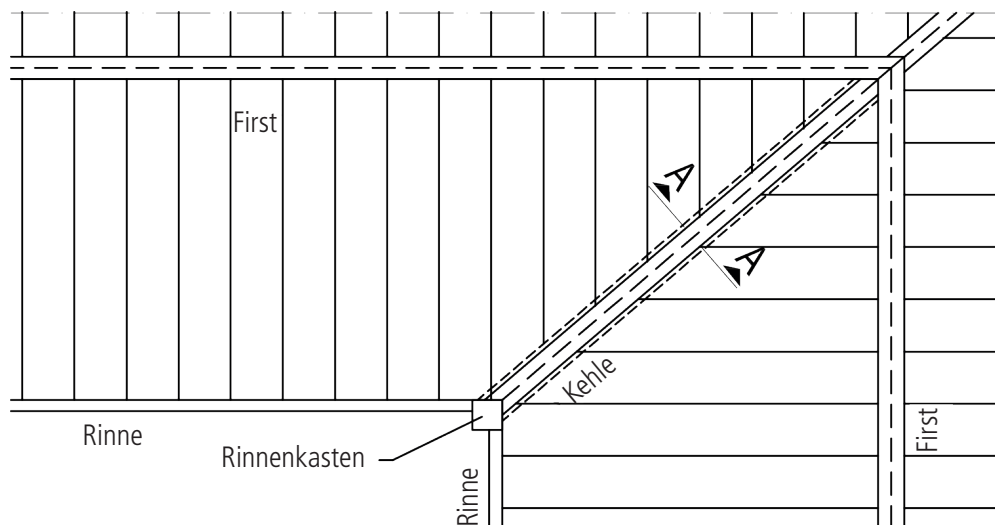
DETAIL KEHLE**VERTIKALSCHNITT SCHNITT A-A****SCHNITT A-A****ÜBERSICHT**

Zeichnungsnummer: 03.07.01/-

Änderungen vorbehalten · Stand 03/21



HIPERTEC DACH

Anwendung: Dach
 Verlegerichtung: -

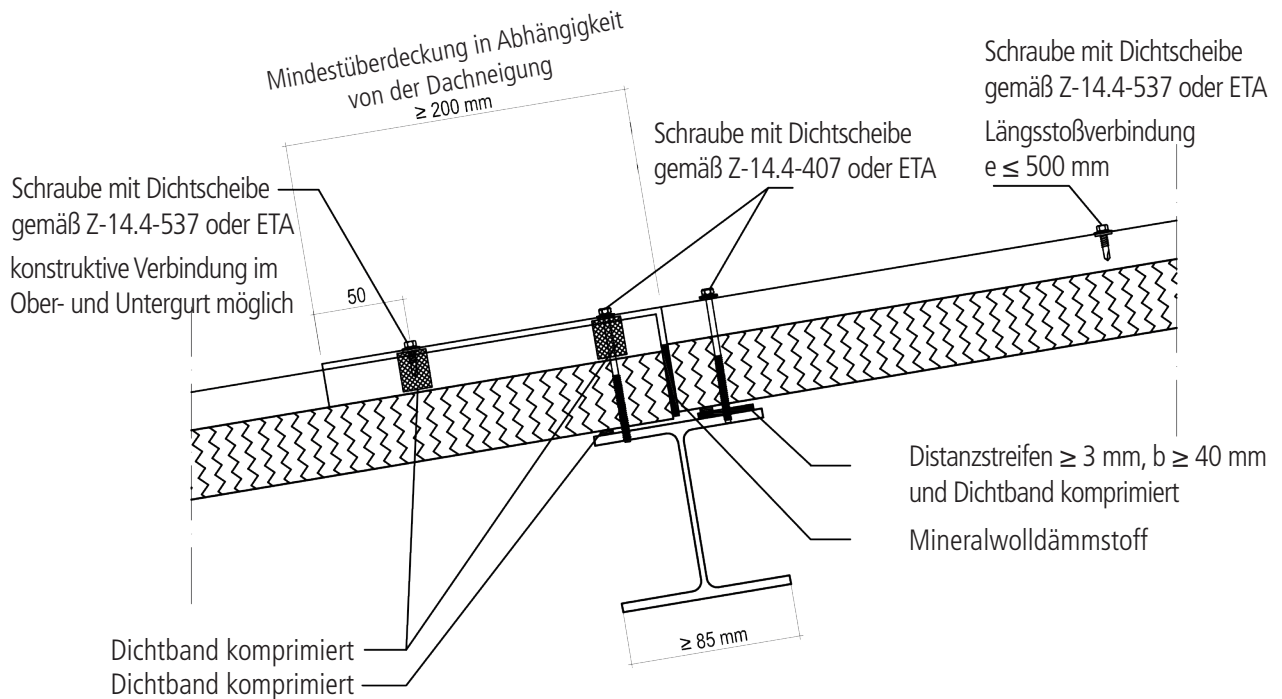
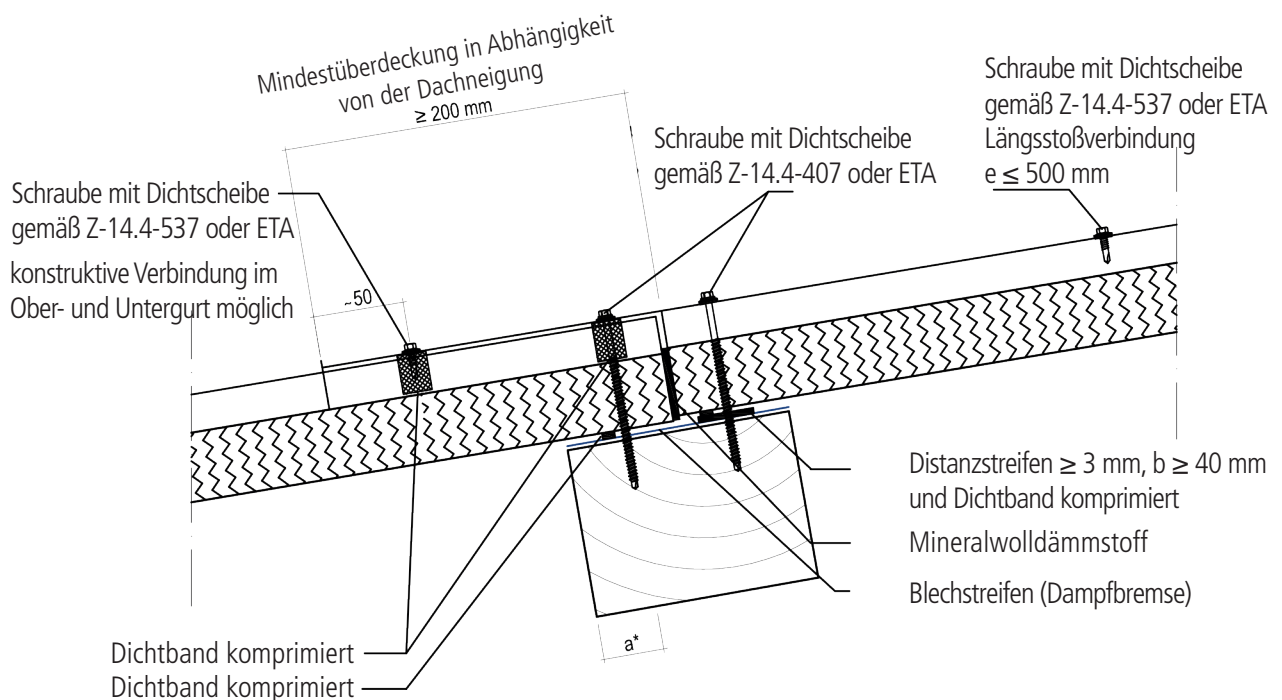
DETAIL QUERSTOSS**VERTIKALSCHNITT QUERSTOSS****Variante: Unterkonstruktion Stahl****VERTIKALSCHNITT QUERSTOSS****Variante: Unterkonstruktion Holz**

a* Randabstand bei Holzpfette $\geq 5 \times$ Schraubenschaftdurchmesser

Zeichnungsnummer: 03.08.01/-

Änderungen vorbehalten · Stand 03/21



HIPERTEC DACH

Anwendung: Dach
 Verlegerichtung: -

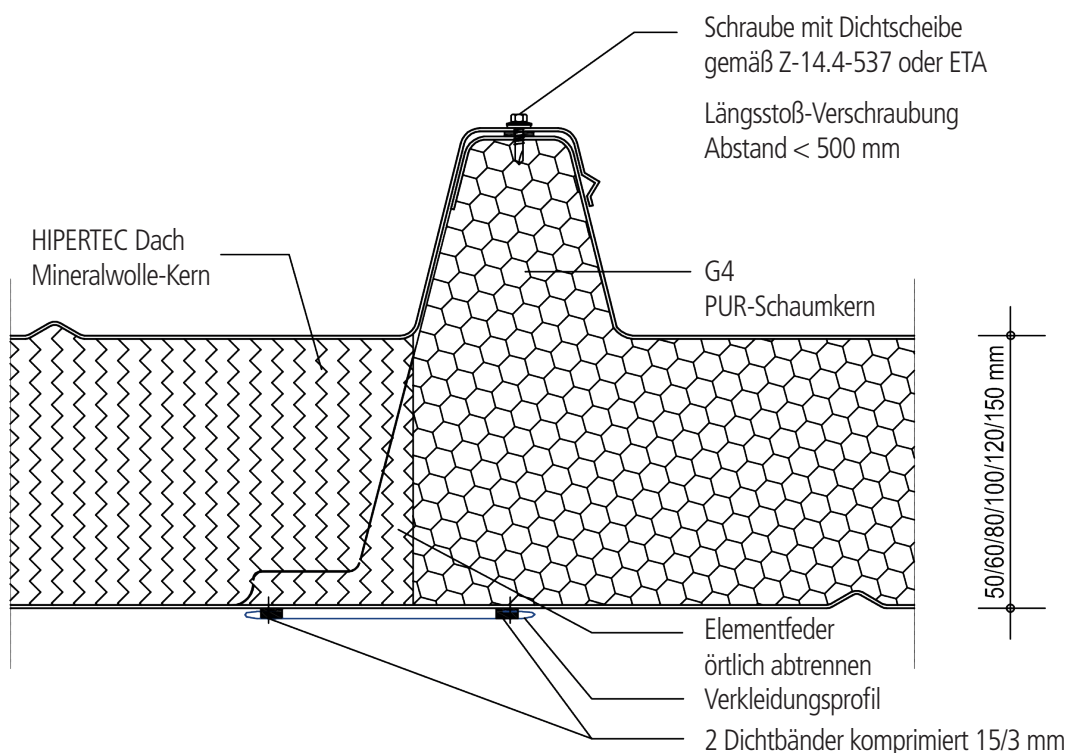
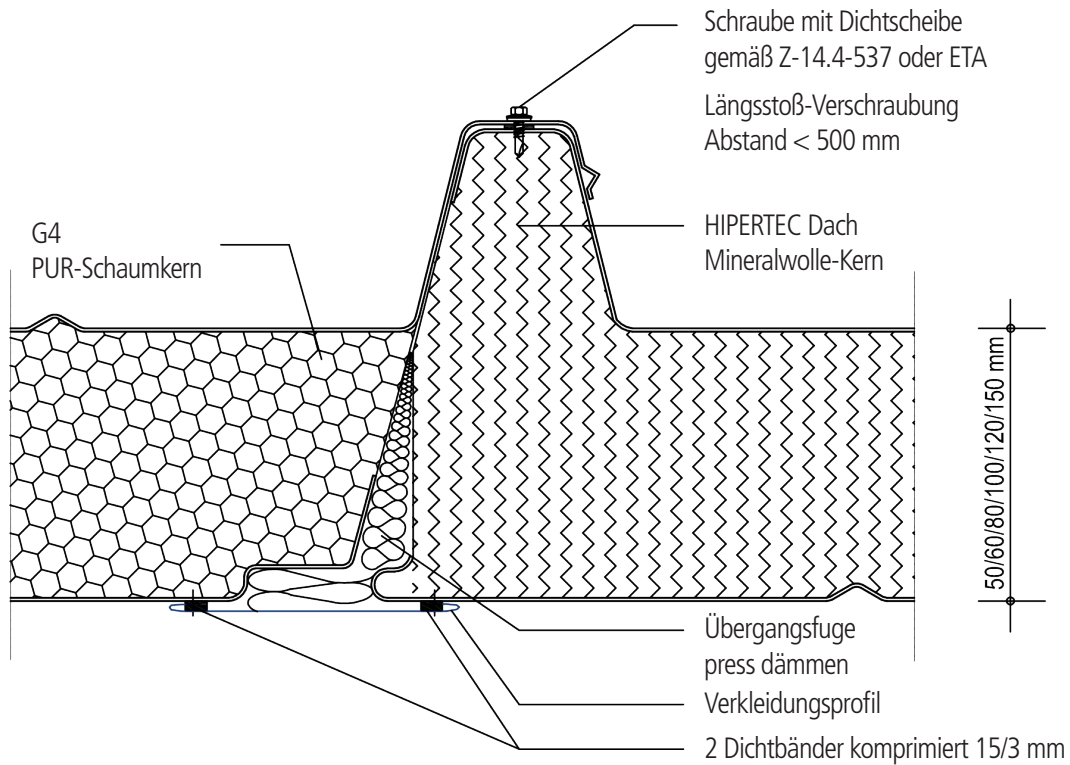
DETAIL VERBINDUNG LÄNGSFUGE**VERTIKALSCHNITT VERBINDUNG LÄNGSFUGE**

Zeichnungsnummer: XX.08.05/-

Änderungen vorbehalten · Stand 03/21

